



# FEED AND POWER HAND PUMP HP 5012 / HP 5016

ENGINEERING

1

Ref. No. P04911  
Release 07/2003

## Description

Automatic change-over from high discharge at low pressure to low discharge at high pressure. Heavyduty construction with hardened and ground piston. Renewable Suction, Delivery, Relief, and Release valve parts. Integral Relief and Release valves. Collapsible hand lever for compact size and short hand movement at low pressure.

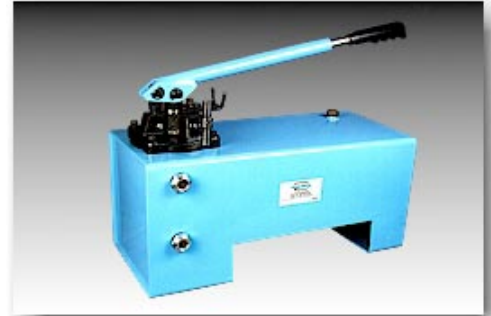

## Section

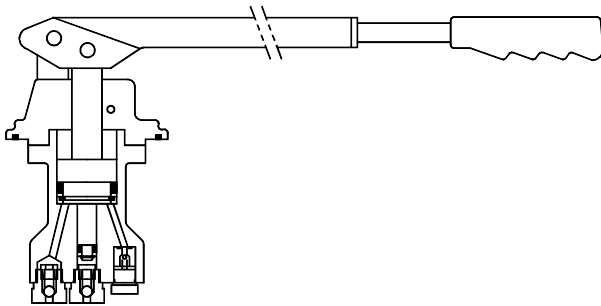

## Hydraulic Symbol

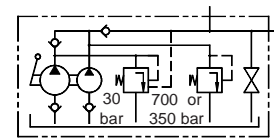

## Unit dimension

### Pump cartridge

Dimensions in mm.

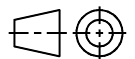
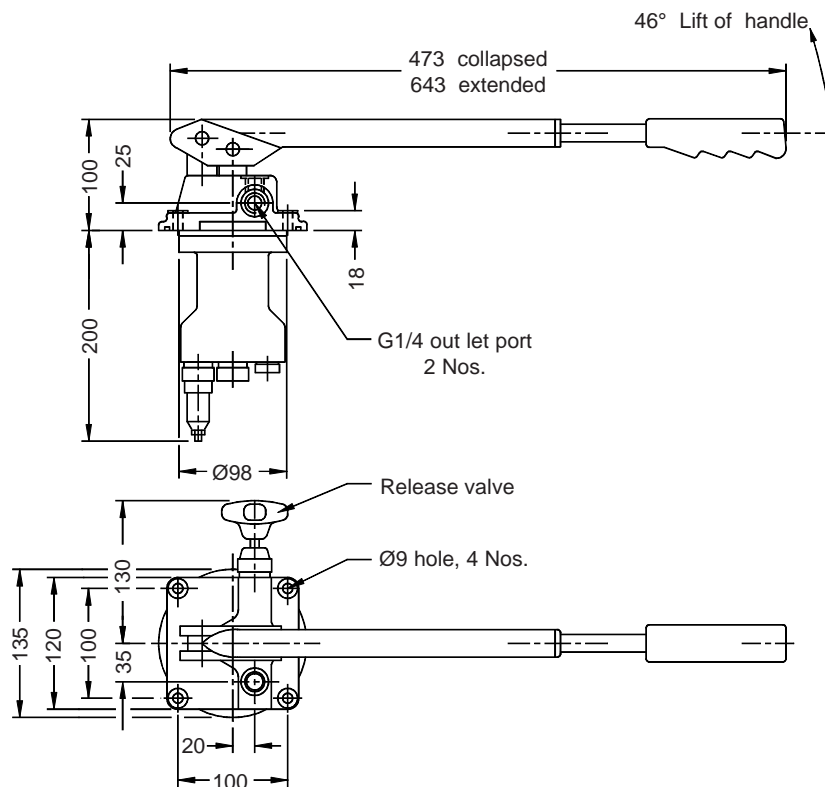

### Polyhydron Pvt. Ltd.

78-80, Machhe Industrial Estate,  
Machhe, Belgaum - 590 014. INDIA.

Phone : +91-(0)831-411001  
Fax : +91-(0)831-411002  
E-mail : polyhydron@vsnl.com  
Website : www.polyhydron.com



Sectional View and Part List

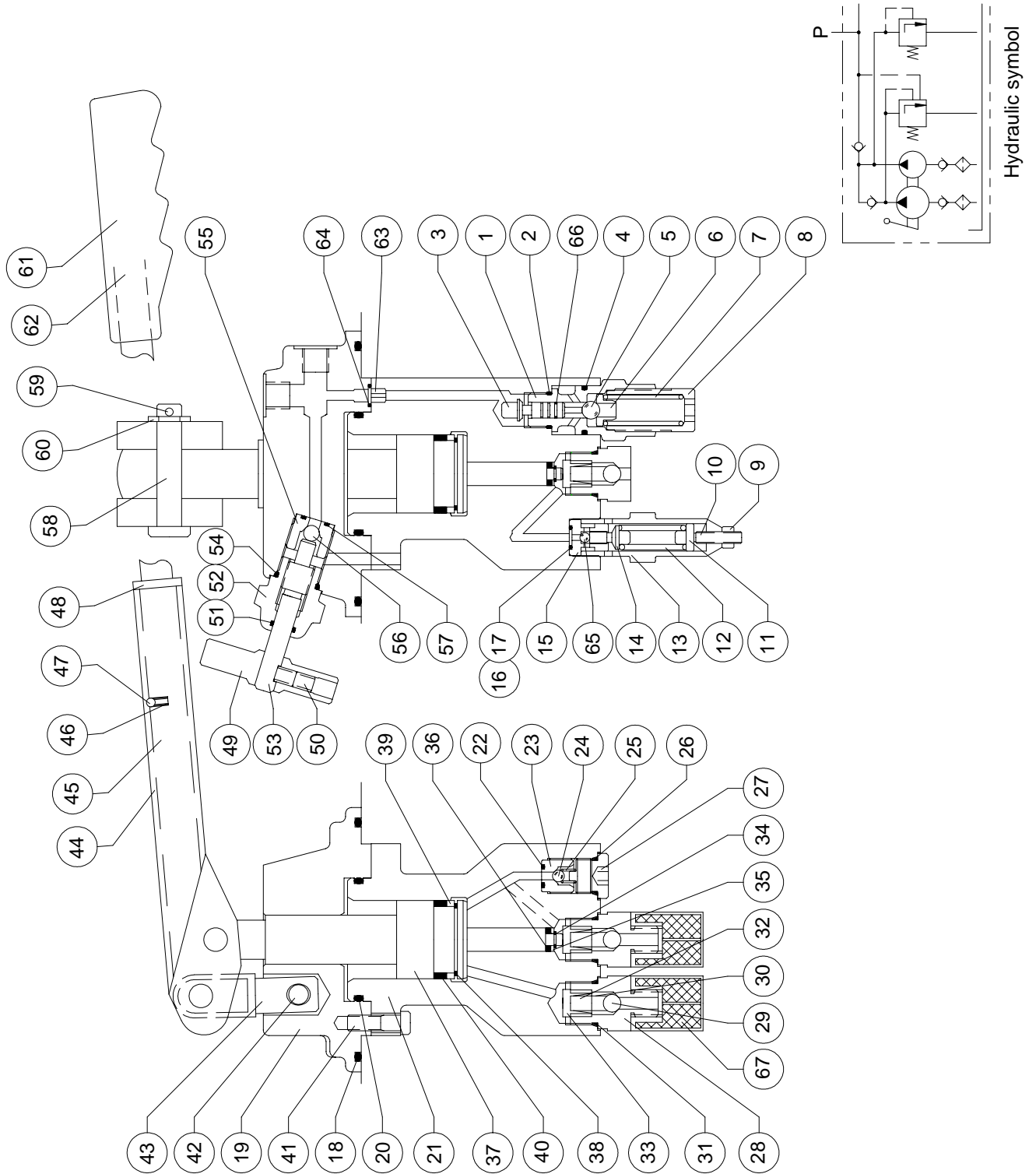



**FEED AND POWER  
HAND PUMP  
HP 5012 / HP 5016**

**SERVICE**

**4**

**Ref. No. P04911**

Part no.	Description	Qty.	Part no.	Description	Qty.
1	Unloading valve housing	1	□ 34	Circlip external (Ø5) HP12	1
* 2	O' Ring (15 i.d.x Ø2.5)	1	35	Spacer (Ø6) HP16	1
3	Pusher pin	1	* 36	Seal fabric (12 o.d x 6 i.d x 7 th) HP12	1
* 4	O' Ring (20 i.d.x Ø2.65)	1	37	Seal fabric (16 o.d x 8 i.d x 8 th) HP16	1
5	Ball	1	38	Piston	1
6	Spring pad	1	39	Circlip external	1
□ 7	Spring unloader	1	* 40	Spacer	1
8	Spring holder	1	41	Seal fabric (50 o.d x 40 i.d x 9 th)	1
9	Nut	1	42	Cap screw with Spring washer	3
10	Socket head cap screw	1	43	Pin	1
11	Spring pad	1	44	Link	1
□ 12	Spring Relief	1	45	Yoke	1
13	Spring casing	1	46	Handle rod	1
14	Poppet	1	47	Spring detension	1
15	Relief valve seat	1	48	Ball	1
* 16	Backup ring (12 x 8 x 1.5 th)	1	49	Guide screw	1
* 17	O' Ring (4.5 i.d.x 1.8 c.s.d.)	1	50	Lever	1
* 18	O' Ring (117 i .d.x 3.55 c.s.d.)	1	51	Grub screw	2
19	Front cover	1	* 52	O' Ring (10 i.d x 1.8 c.s.d)	1
* 20	O' Ring (58 i.d.x 3.55 c.s.d.)	1	53	Guide	1
21	Housing	1	54	Spindle	1
* 22	O' Ring (7.1 i.d.x1.8c.s.d.)	2	* 55	O' Ring (19 i.d x 2.5 c.s.d)	1
23	Delivery valve seat	2	56	Release valve seat	1
24	Ball	2	57	Ball	1
□ 25	Spring delivery	2	* 58	O' Ring (10 i.d x 1.8 c.s.d)	1
* 26	O' Ring (15 i.d.x 2.5 c.s.d.)	2	59	Pin	2
27	Spring guide	2	60	Split cotter pin	2
28	Suction valve housing	2	61	Spacer	2
29	Ball	2	62	Grip	1
□ 30	Spring suction	2	63	Grip holder	1
* 31	O' Ring (19 i.d.x 2.5 c.s.d.)	2	64	Spring dowel	1
32	Spring guide	2	* 65	O' Ring (7.1 i.d x 1.8 c.s.d)	1
33	Screw	2	66	Steel ball	1
			* 67	O' Ring (4.5 i.d x 1.8 c.s.d)	1
				Suction strainer	2

Note : \* Recommended seal kit.      \*, □ Recommended spare kit.

While ordering the individual spares/seal kit/spare kit give part.no.  
and complete details of model code as punched on the pump body.